

LED High Intensity Aviation Obstacle Lights

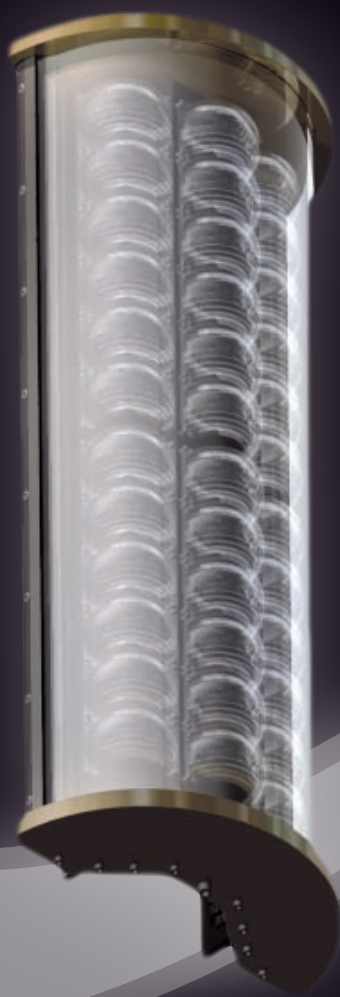

LED High Intensity Aviation Obstacle Lighting System

Obelux LED High Intensity Aviation Obstacle Lighting System is based on state-of-the-art technology and it has been designed for the obstacle lighting of tall buildings, communication towers, broadcast masts, smoke stacks, wind turbines, and other tall constructions.

LED High Intensity Aviation Obstacle Light is designed to replace old Xenon technology on over 150 meter tall constructions and masts which have normally required almost yearly maintenance. Due to the state-of-the-art design and the outstanding performance, the new LED High Intensity Aviation Obstacle Light provides over 10 years of reliable life without the fear of unplanned site visits and high maintenance costs.

All Obelux's products are offered an exclusive 5-year warranty – the longest in the industry.



Key Features

- Based on LED technology
- 200 000/20 000/2 000cd effective flashing white (ICAO)
- 120° x 3° beam spread
- Long maintenance free operating time
- Controlled by Obelux Light Head Controller (LHC)
- ICAO and FAA Compliant

Typical lighting configuration

Normally, the lighting system of a tall construction constitutes of 2-5 levels. One Light Head (LH) produces a light beam of 120° which means that three of them are required to install on a one level to cover the full 360°. One Light Head Controller (LHC), which can control one to three Light Heads, is installed per level.

Light Head Controller's function is both to offer sufficient and stable power to the Light Heads and to monitor and control them in many ways. In principal, Light Head Controller contains Power Supply (PS) and Control Module (COM). Control Module controls the flashing frequency (20/40/60 fpm) and alarm generation. Light Head Controller has both a stand-alone and a centrally controlled operating mode. The system has an optional Control Panel (CP) which communicates with the whole system through Ethernet or RS-485 interface. Control Panel is located generally on the ground floor.

ICAO and FAA compliant

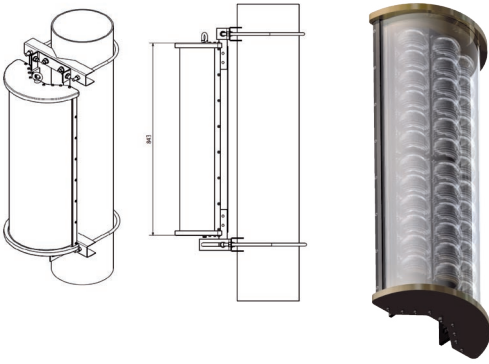

Light head (LH)

- 120° beam spread
- 255 W power consumption, @ 40 fpm, day mode
- Flashing White (20-60 fpm)
- 200 000 cd at day, 20 000 cd at twilight, 2 000 cd at night
- Weight 27 kg
- Height 843 mm, width 353 mm, depth 213 mm (ICAO type)
- Mounting set included (hot dip galvanized steel)



Light Head Controller (LHC)

- Controls up to 3 Light Heads
- Cabinet includes an active PFC Power Supply (PS) and Controller Module (COM)
- Fault monitoring and flash synchronization
- Options for GPS flash synchronization, GSM communication, and Ethernet data communication
- Nominal operating voltage 230 VAC
- Two isolated RS-485 interfaces and two Ethernet ports
- IP communication
- Over voltage protection
- Fiber optic communication as option
- Mounting set included



Control Panel (CP)

- Includes a Controller Module (COM) and a LCD display
- Displays system status
- Sets system parameters
- Provides sync and lux information for system
- GPS synchronization as option
- Provides an alarm signal with relay
- Fiber optic communication as option

The lighting system is extremely easy to install and it has additional options for GSM controlling and fault reporting, GPS Flash Synchronization, and Internet connection among others.



**Headquarters, R&D,
Manufacturing,
Domestic and
International sales**

Obelux Oy
Kutomotie 6B
FI-00380 Helsinki
Finland

Tel +358 9 6871 6800
Fax +358 9 621 5518
E-mail info@obelux.com
www.obelux.com